

AquaFlow

Indirect unvented
cylinders



SINGLE COIL 120 - 150 - 180 - 200 - 250 - 300 ■

TWIN COIL 200 - 250 - 300 ■

25 YEAR TANK WARRANTY ■

BUILDING & WATER REGULATIONS APPROVED ■

HIGH QUALITY STAINLESS STEEL ■

HIGH PERFORMANCE ■

AquaFlow

Indirect unvented cylinders

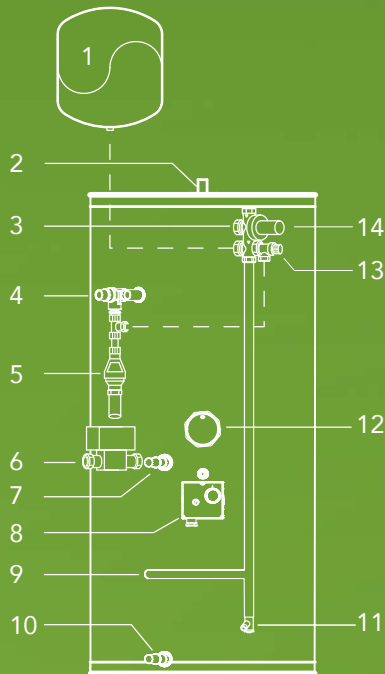

KEY

1. Expansion vessel
2. Hot water draw off
3. Balanced pressure cold outlet
4. Temperature and pressure relief valve (90°C / 7bar)
5. Tundish
6. 2-port motorised valve
7. Heating flow
8. Thermostat / energy cut off
9. Cold water inlet
10. Heating return
11. Drain valve
12. Immersion heater
13. Expansion relief valve
14. Pressure reducing valve (3.5bar) with inline strainer

AquaFlow indirect single coil shown

- For use with Vokera Mynute VHE open vent boiler, Vision S and Mynute i system boilers.
- Inner tank guaranteed for 25 years⁽¹⁾, made from 444 stainless steel.
- 2 year warranty on ancillary components⁽¹⁾.
- Indirect single coil and twin coil (for use with Vokera Zenith solar thermal) versions.
- High performance mains pressure to all hot water outlets.
- Up to 50 l/min flow rate.
- Building and water regulations approved.
- No need for 'sacrificial anode' due to excellent anti-corrosion properties of stainless steel.
- Compact dimensions.
- TPRV, EV, Water controls, Tundish, 2-port motorised valve supplied as standard.
- 3kW immersion heater and energy cut-out device supplied as standard.
- Optional secondary return connection if required.
- Thermal insulation and energy efficient coil meet Part L Requirements.

⁽¹⁾Subject to registration and annual service, 25 year warranty on the tank, 2 year warranty on ancillary parts.



ErP Compliant



25 Year Warranty⁽¹⁾



BUILDING AND WATER REGULATIONS APPROVED



COMPATIBLE WITH MYNUTE AND VISION S

SPECIFICATIONS	AQUA FLOW 120 SC	AQUA FLOW 150 SC	AQUA FLOW 180 SC	AQUA FLOW 200 SC	AQUA FLOW 250 SC	AQUA FLOW 300 SC
PRODUCT ORDER CODE	29450020	29450021	29450022	29450023	29450024	29450025
NOMINAL CAPACITY (LITRES)	120	150	180	200	250	300
DIMENSIONS AND WEIGHTS						
HEIGHT (MM)	1001	1191	1371	1593	1843	2153
DIAMETER (MM)	555	555	555	555	555	555
WEIGHT WHEN EMPTY (KG)	26.8	28.9	32.4	36.8	40.7	45.9
WEIGHT WHEN FULL (KG)	146	178	209	248	291	345
PERFORMANCE						
COIL RATING (kW)	18.4	18.8	22.0	22.6	22.3	20.9
COIL SURFACE AREA (M ²)	0.62	0.62	0.75	0.75	0.75	0.75
REHEAT TIME 15°C - 60°C (MIN)	18	23	24	28	35	41
EFFICIENCY						
HEAT LOSS (W)	51	60	67	77	89	103
MAX WORKING PRESSURE (BAR)	6	6	6	6	6	6
ErP RATING	B	C	C	C	C	D

SPECIFICATIONS	AQUA FLOW 200 TC	AQUA FLOW 250 TC	AQUA FLOW 300 TC
PRODUCT ORDER CODE	29450026	29450027	29450028
NOMINAL CAPACITY (LITRES)	200	250	300
DIMENSIONS AND WEIGHTS			
HEIGHT (MM)	1593	1843	2153
DIAMETER (MM)	555	555	555
WEIGHT WHEN EMPTY (KG)	50	43	50
WEIGHT WHEN FULL (KG)	246	288	343
PERFORMANCE			
UPPER COIL RATING (kW)	15.7	15.6	15.5
UPPER COIL SURFACE AREA (M ²)	0.5	0.5	0.5
LOWER COIL RATING (kW)	18.6	18.4	17.1
LOWER COIL SURFACE AREA (M ²)	0.62	0.62	0.62
EFFICIENCY			
HEAT LOSS (W)	79	91	105
MAX WORKING PRESSURE (BAR)	6	6	6
ErP RATING	C	C	D

GET IN TOUCH Vokera Limited, Borderlake House, Unit 7 Riverside Industrial Estate, London Colney, AL2 1HG
E: enquiries@vokera.co.uk **T:** 0844 391 0999
W: www.vokera.co.uk **F:** 0844 391 0998

WE ARE SOCIAL

